

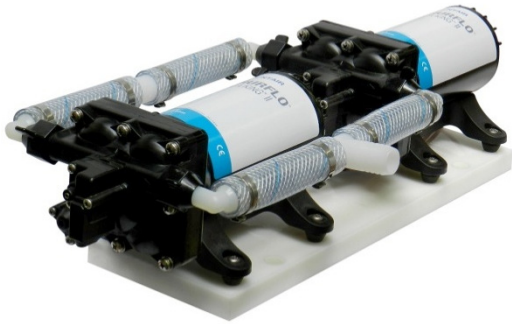

# SHURFLO HIGH FLOW SYSTEM™ II 10.0 GPM

## MARINE FRESH WATER SYSTEM – PRODUCT TECHNICAL DATA SHEET

OEM: 4558-163-E75  
 AFTERMARKET: 4558-163-E75



### APPLICATION:

Multi-fixture Marine fresh water system installation.  
 This system may be used for general fresh water transfer

### PUMP DESIGN:

Type: 4 Chamber Diaphragm pump  
 Pump Ports: 1/2" -14 NPSM-Male  
 Manifold: 3/4" Barb  
 Liquid: 130°F [54°C] Max  
 Dry-Prime: 6 feet [1.82 M]  
 Run Dry: Yes  
 Inlet Pressure: 30 PSI Max. [2.06 Bar]

### ELECTRICAL:

Motor: 24V DC Permanent Magnet, Intermittent Duty.  
 Protection: Thermal Overload, Automatic Restart  
 Leads: 14 AWG, 14-3/4" [37 cm] Red +, 15" [38 cm] Black  
 Fuse: Primary pump 7.5 Amp Recommended,  
 Secondary pump 7.5 Amp Recommended,  
 Both pumps together: 15 Amps Recommended.  
 Control: Primary pump: Shut-Off 55 PSI [3.8 Bar]  
 ± 2 PSI [0.13 Bar] Re-start 40 PSI [2.8 Bar]  
 ± 2 PSI [0.13 Bar] Maximum By-Pass 65 PSI  
 [4.5 Bar] ± 2 PSI [0.13 Bar]  
 Secondary pump: Shut-Off 45 PSI  
 [3.1 Bar] ± 2 PSI [0.13 Bar] Re-start 30 PSI [2 Bar]

### MATERIALS OF CONSTRUCTION:

Housings: Polypro  
 Valves/Seals: EPDM  
 Diaphragm: Santoprene  
 Hardware: Stainless Steel

### AGENCY APPROVALS:

Ignition Protection 8846, CE, IMCI Certified

### REPAIR KITS

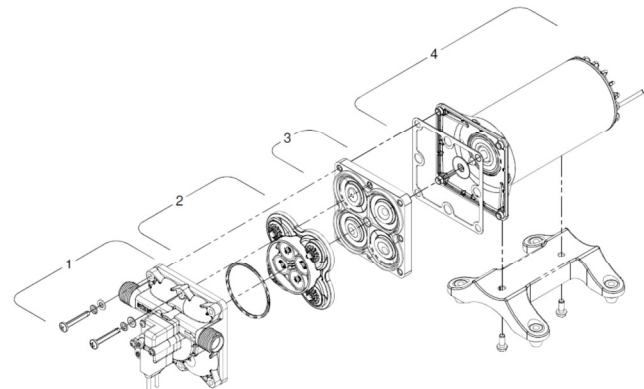

Number	4158-163-E75	4258-163-E07
*1	94-801-10	94-805-01
2	94-800-01	94-800-01
3	94-801-12	94-801-02
4	94-71-001-04	94-71-001-04
*1,2,3	94-801-13	94-805-02
Check valve (Not Shown)	94-800-03	94-800-03

\*With preset switch and by-pass adjustment (if applicable)

**SHIPPING INFORMATION:**

Approx. Net Weight: 20 Pounds [9.0 Kg] ea.  
 Carton Qty.: 1  
 Approx. Carton Size: 24”L X 18”W X 6”H [61cm x 46cm x 15cm]

**RELATED DOCUMENTS:**

Catalog: MS-030-140  
 App Guide Sheet : MS-020-005  
 Installation Manual: 911-1049  
 Aftermarket Warranty: 911-1045

**TYPICAL PERFORMANCE AT 25.6V**

PRESSURE		FLOW		TOTAL	4158-163-E75	4258-163-E07
BAR	PSI	GPM	LPM	AMPS	AMPS	AMPS
0	0	10	37.8	5.6	2.5	3.1
0.7	10	9.0	34.0	7.2	3.2	3.9
1.4	20	7.6	28.7	8.5	3.8	4.6
2.1	30	6.4	24.2	9.7	4.3	5.3
2.8	40	5.5	20.8	10.9	4.5	6.0
3.4	50	0.8	3.0		5.5	

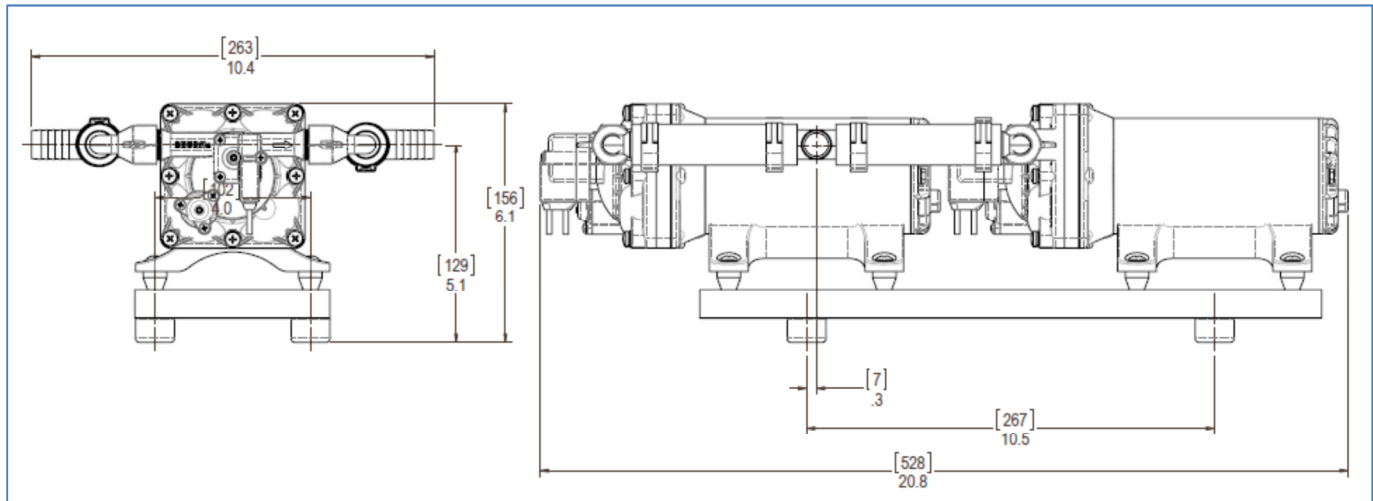

**WATER PURIFICATION**

3545 Harbor Gateway South, Suite 103, Costa Mesa, CA 92626, (800) 854-3218 www.SHURFLO.com

All Pentair trademarks and logos are owned by Pentair, Inc. All other brand or product names are trademarks or registered marks of their respective owners. Because we are continuously improving our products and services, Pentair reserves the right to change specifications without prior notice. Pentair is an equal opportunity employer.

# SHURFLO® HIGH FLOW SYSTEM™ II (10 GPM)

## MARINE FRESH WATER DUAL PUMP SYSTEM

MODEL SERIES 4558

### IMPORTANT - READ INSTRUCTIONS BEFORE INSTALLING THE HIGH FLOW SYSTEM II

Congratulations! You have purchased the finest fresh water dual pump system in the industry. The High Flow System II has been designed and engineered to provide you with "just like home" water flow up to 10 gallons per minute.

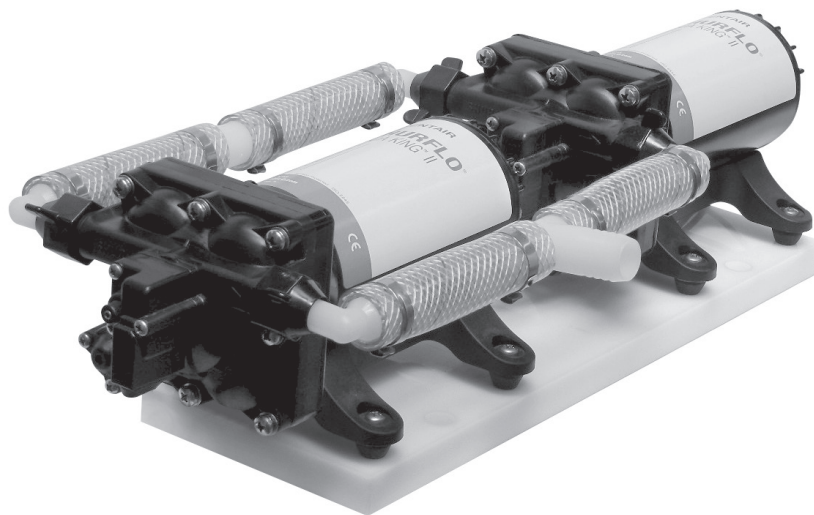

### ELECTRICAL

■ The pumps should be on a dedicated (individual) circuit protected by the specified fuse indicated on the motor label.

**NOTE:** If both pumps are installed on the same circuit be aware of the total current generated by both pumps. Use the appropriate fuse size and wire gauge to protect both pumps (Total current draw x 113% = fuse size).

■ A U/L approved marine duty switch (ignition protected) is recommended, and must interrupt current flow on the positive (+ red) lead.

Ft. [meters]		AWG [mm <sup>2</sup> ]	
0-20	[0-6]	14	[2.5]
20-50	[6-15]	12	4
50-70	[15-21]	10	[6]
70-100	[21-30]	8	[8]

Minimum Wire Size for a 10% voltage drop on a 12VDC, 15 Amp Circuit. Length is the distance from the power source to pump and back to ground.

### MOUNTING

- Mount system within 6 feet of the tank for best performance.
- Mount system for easy access if maintenance is required.
- Mount system in a space of one cubic foot unless adequate ventilation is provided.
- The system may be mounted in any position.
- Choose a solid surface for mounting.
- The mounting feet are intended to isolate the system from the mounting surface; over tightening, or use of oversized screws will reduce ability to isolate vibration/noise.

### PLUMBING

**Reducing unnecessary restrictions to the inlet and the outlet tubing will allow the system to run freely, maximizing performance, quietness and eliminate the possibility of cavitation (starving the pumps).**

- Installation of a 50 mesh strainer to each pump, such as SHURFLO model 255 is recommended to prevent debris from entering the pumps.
- System may flow better with 3/4" line feeding the pumps.

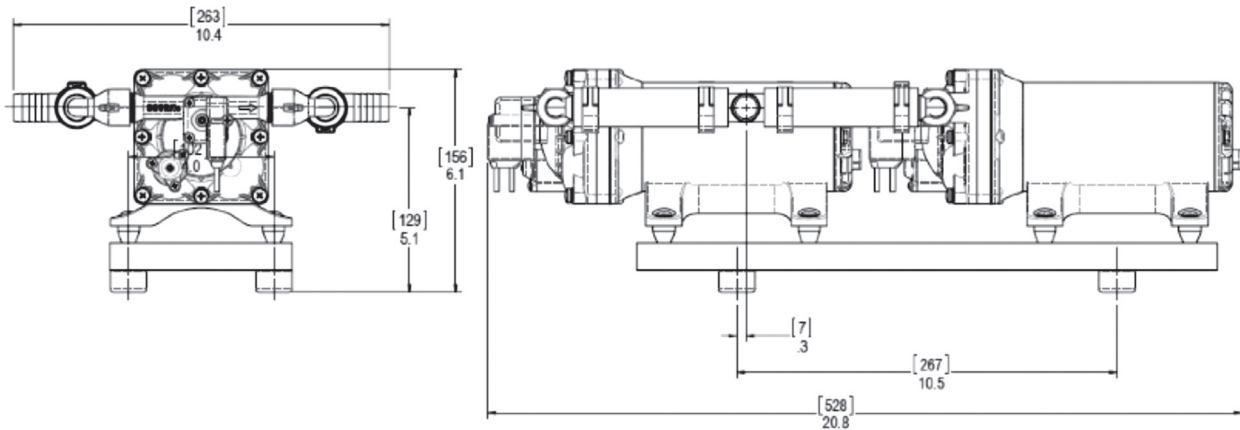

## OPERATION

This system is designed for intermittent duty only. The primary pump (located in front) activates when system pressure drops to about 40 PSI [2.8 BAR]. The secondary pump activates when flow demand is about 5 GPM. The secondary pump (located in the back) shuts off when the pressure increases to about 45 PSI and the secondary pump shuts off when the pressure increases to about 55 PSI. **Primary pump operation with by-pass:** this pump operates normally up to about 30 PSI [2.06 BAR], where a spring-loaded by-pass valve opens, allowing flow back from the output side to

the input side, providing smooth, steady flow with virtually no cycling, all the way down to a trickle. As a faucet is opened back up, the pressure will drop, the by-pass will close and full flow is again obtained. This allows good flow, even with today's restrictive showers and pullout sprayer faucets. Performance will vary, of course, depending on the voltage to the pump; lower voltage = lower flow, higher voltage = higher flow. Remember your electrical safety: It is always best to shut power to the system "OFF" when leaving the Boat unattended.

**WARNING: If full by-pass is reached before the shut-off setting, the pump will not shut off.** Full by-pass pressure setting should be at least 10 PSI [0.68 BAR] higher than pump shut off pressure.

## MAINTENANCE

Normal pump maintenance is all that is needed: Checking and cleaning of the strainer, normal sanitizing and winterizing and occasionally checking all plumbing hardware and fittings for tightness. Lack of sanitizing is the number one reason for premature pump failure and poor performance over time. Lack of sanitizing will cause scale build-up on the diaphragm and valves, causing low flow and leak back [occasional pump cycling with no faucets open or tank filling up when hooked up to city water].

## SANITIZING

Potable water systems require periodic maintenance to keep components working properly and deliver a consistent flow of fresh water. Sanitizing is recommended: prior to storing, after a period of storage, or any time the system is opened or contaminated, as follows: **NOTE: Check your Boat Owner's Manual for specific instructions. By-pass any filters or remove filter cartridges.**

1. Determine the amount of common household bleach needed to sanitize the tank.

A) 2 ounces of bleach per 15 gallons tank size: 60 gallon tank [15 x 4] = 4 x 2 ounces = 8 ounces of bleach.

B) 1 ml bleach per 1 liter tank size: 300 liter tank = 300 milliliters of bleach.

2. Mix the bleach with water in a container such as a gallon jug. If tank is filled through a pressurized fitting, pour the bleach into the hose before attaching the hose to the city water entry.

3. Pour the bleach solution into the tank and fill the tank with potable water. Rock the boat back and forth to coat top and sides of potable water tank.

4. Open all faucets (Hot & Cold) allowing the water to run until the odor of chlorine is detected. Allow four (4) hours of contact time to disinfect completely. Doubling the solution concentration allows for a contact time of one (1) hour.

5. Drain the tank. Refill the tank and flush the system once or twice until the odor has decreased. The residual chlorine odor and taste is not harmful.

## WINTERIZING

---

Refer to the boat owner's manual for specific winterizing instructions.

If water is allowed to freeze in the system, serious damage to the plumbing and pump may occur. Failures of this type will void the warranty. The best guarantee against damage is to completely drain the pump and perform the following:

1. Drain the water tank. If the tank doesn't have a drain valve, open all faucets allowing the pump to operate until the tank is empty.
2. Open all the faucets (including the lowest valve or drain in the plumbing), allow the pump to purge the water from the plumbing, and then turn the pump "OFF."
3. Using a pan to catch the remaining water, remove the plumbing at the pump's inlet/outlet ports. Turn the pump "ON", allowing it to operate until the water is expelled. Turn "OFF" power to the pump once the plumbing is emptied. Do not reconnect the pump plumbing. Make a note at tank filler as a reminder: "Plumbing is disconnected".
4. All faucets must be left open to guard against any damage.
5. Potable anti-freeze may be poured down drains and toilets to protect p-traps and toilet seals. Sanitize the plumbing system before putting the plumbing system back in service.

## TROUBLESHOOTING

---

Vibration induced by driving can loosen plumbing, strainers and pump hardware. Check for system components that are loose. Also, refer to the chart below for trouble-shooting tips.

### PUMP WILL NOT START/ BLOWS CIRCUIT

- ✓ Electrical connections, fuse or breaker, main switch, and ground connection.
- ✓ Is the motor hot? Thermal breaker may have triggered; it will reset when cool.
- ✓ Is voltage present at the switch? Bypass pressure sw. Does the pump operate?
- ✓ Charging System for correct voltage ( $\pm 10\%$ ) and good ground.
- ✓ For an open or grounded circuit, or motor; or improperly sized wire.
- ✓ For seized or locked diaphragm assembly (water frozen?).

### WILL NOT PRIME/SPUTTERS (No discharge/Motor runs)

- ✓ Is the strainer clogged with debris?
- ✓ Is there water in the tank, or has air collected in the hot water heater?
- ✓ Is the inlet tubing/plumbing sucking in air at plumbing connections (vacuum leak)?
- ✓ Is inlet/outlet plumbing severely restricted or kinked? Restrictive valves?
- ✓ Proper voltage with the pump operating ( $\pm 10\%$ ).
- ✓ For debris in pump inlet/outlet valves or swollen/dry valves.
- ✓ Pump housing for cracks or loose drive assembly screws.

### RAPID CYCLING

- ✓ For restrictive plumbing and flow restrictions in faucets/shower heads.
- ✓ Water filter/purifier should be on separate feed line.
- ✓ Shut-off pressure set too low.

### PUMP WILL NOT SHUT-OFF / RUNS WHEN FAUCET IS CLOSED

- ✓ Output side (pressure) plumbing for leaks, and inspect for leaky valves or toilet.
- ✓ For air trapped in outlet side (water heater) or pump head.
- ✓ For correct voltage to pump ( $\pm 10\%$ ).
- ✓ For loose drive assembly or pump head screws.
- ✓ Are the valves held open by debris or is the rubber swollen?
- ✓ Pressure switch operation. By-pass set higher than shut-off.

### NOISY OR ROUGH OPERATION

- ✓ For plumbing which may have vibrated loose.
- ✓ For a restricted inlet (clogged strainer, kinked hose, restrictive valves).
- ✓ Is the pump plumbed with rigid pipe causing noise to transmit?
- ✓ Does the mounting surface amplify noise (flexible)? Does it bang like a drum?
- ✓ For mounting feet that are loose or are compressed too tight.
- ✓ For air in the system. Check all fixtures for air and bleed system.
- ✓ The motor with pump head removed. Is noise from motor or pump head?

### LEAKS FROM PUMP HEAD OR SWITCH

- ✓ For loose screws at switch or pump head.
- ✓ Switch diaphragm ruptured or pinched.
- ✓ For punctured diaphragm if water is present in drive assembly.

## SERVICE KITS

ITEM	4158-153-E75 PART #	4258-153-E07 PART #	4158-163-E75 PART #	4258-163-E07 PART #
1	94-801-10*	94-805-01*	94-801-10*	94-805-01*
2	94-800-01	94-800-01	94-800-01	94-800-01
3	94-801-12	94-801-02	94-801-12	94-801-02
4	94-71-000-17	94-71-004-17	94-71-001-04	94-71-001-04
1, 2, 3	94-801-13*	94-805-02*	94-801-13*	94-805-02*
<b>Check Valve</b> (not shown)	94-800-03	94-800-03	94-800-03	94-800-03

\*With preset switch and by-pass adjustment (if applicable)

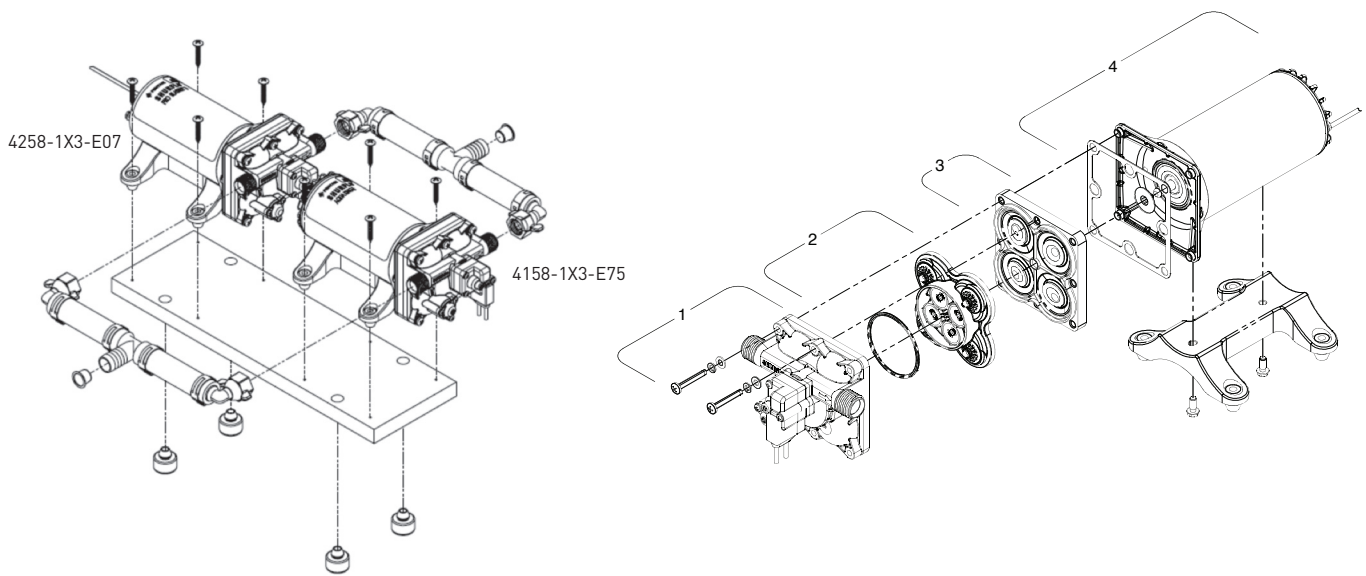

3545 HARBOR GATEWAY SOUTH, SUITE 103, COSTA MESA, CA 92626, (800) 854-3218 WWW.SHURFLO.COM

All Pentair trademarks and logos are owned by Pentair, Inc. All other brand or product names are trademarks or registered marks of their respective owners. Because we are continuously improving our products and services, Pentair reserves the right to change specifications without prior notice. Pentair is an equal opportunity employer.

911-1049 Rev. D 06/15 ©Pentair, Inc. All Rights Reserved.