

3371-0028

Jet Agitator Has Advantages

Hypro's new high-volume jet agitator assures thorough mixing in large spraying equipment tanks. This jet agitator Model 3371-0028 can inexpensively increase output flow for agitation up to 5-1/2 times. Three snap-in orifices—1/4", 9/32" and 5/16"—help optimize inlet flows. With 3/4" NPT fittings, the agitator can easily be retrofitted to replace smaller Hypro agitators.



Comprised of glass-filled polypropylene, Model 3371-0028 is highly resistant to corrosion and wear. It's a lasting investment that produces greater effectiveness in crop spraying and, ultimately, leads to higher yields.

Hypro's Superior Characteristics

- **Glass-filled polypropylene construction for excellent corrosion and wear resistance**
- **3/4" NPT fittings for easy retrofitting of smaller Hypro agitators**
- **Larger agitator than the competition (still fits through the same openings)**
- **Three snap-in orifices for optimization of inlet flows**

3371-0028 Accessory

High-Volume Jet Agitator

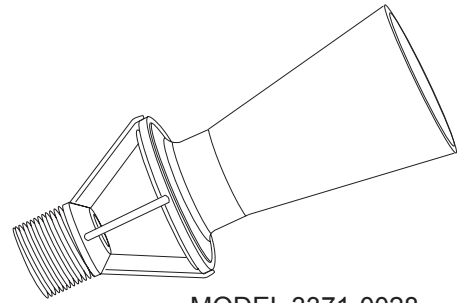

MODEL 3371-0028

- Increases effective output flow up to 5.5 times the input for thorough agitation.

AGITATION

Thorough mixing of large volume tanks is achieved using the Hypro high-volume jet agitator. The agitation patterns shown below illustrate the full flow achieved with the volume boosting capacity of the agitator.

To be effective, the jet agitator bypass must be on a separate line, not on the end of the relief valve bypass line. An adjustable hand valve is necessary to regulate pressure and flow to the agitator.

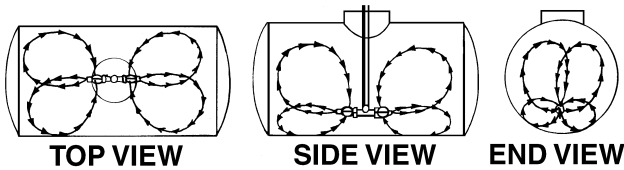

3371-0028 With 1/4" Nozzle Performance

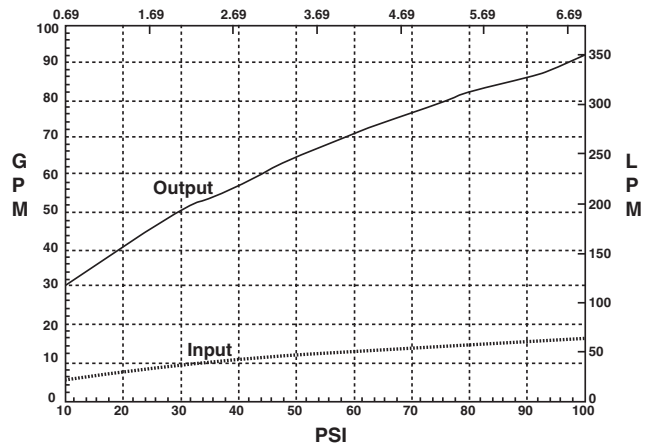

NOZZLE SELECTION

The correct nozzle will provide ample agitation to maintain solution suspension. The three nozzles are easily interchangeable by snapping in and snapping out of the agitator body. Check the three performance graphs to find the proper nozzle size for the desired volume.

3371-0028 With 9/32" Nozzle Performance

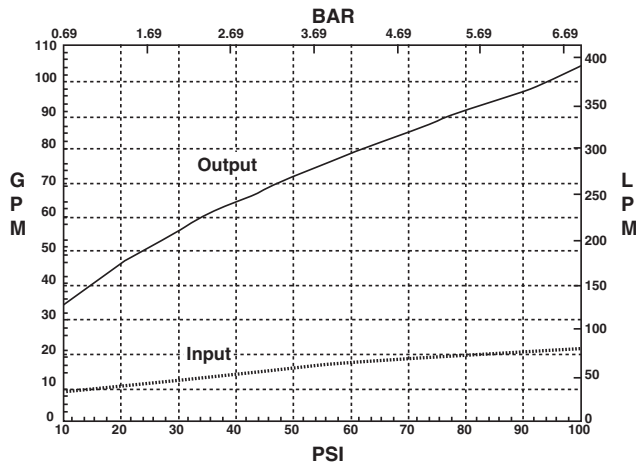

3371-0028 With 5/16" Nozzle Performance

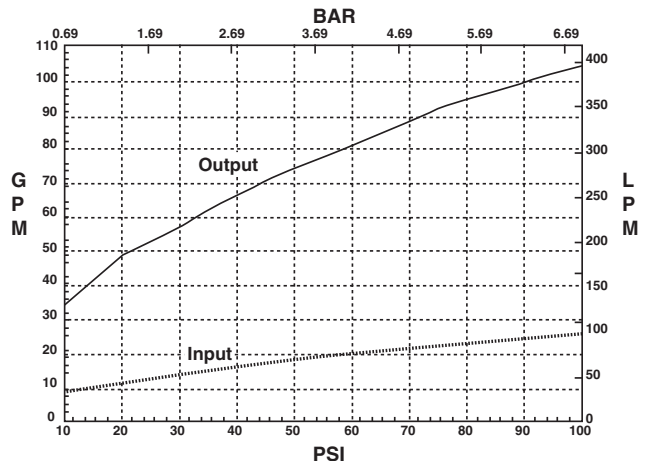

Pentair

SPRAY & INJECTION TECHNOLOGIES GROUP

375 Fifth Avenue NW • New Brighton, MN 55112

Phone: (651) 766-6300 • 800-424-9776 • Fax: 800-323-6496

www.hypropumps.com